

ARMOURING



Armoured Vehicles  
for Military Professionals



# ARMOURED MILITARY VEHICLES



OUR  
KONSTRUCTIONS  
IN MOTION

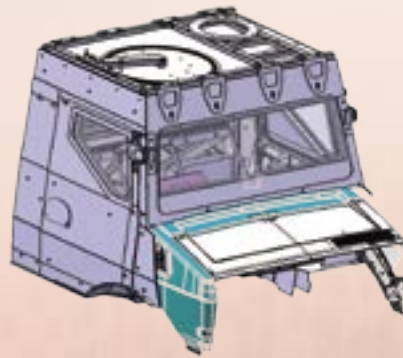

When safety is at stake, nothing can be left to chance. We at Ressenig are therefore dedicated to achieving top quality in all our safety features and subjecting the materials used to stringent endurance tests. Planning and development form an integral part of our work, which is why we use the latest applications and can tailor our products to customer specifications.





This complete cycle consisting of research & development, production, quality and service for the clients is an art practised with naturalness and approved constantly.

We consider ourselves to be a competent development partner from the concept up to the readiness for series production and as a flexible partner for production of prototypes, individual items and series productions.

Both competences are united under one roof to be flexible to react to the requirements and to give the client and end-user security through quality.



With excellent quality you drive safely ...

# ARMOURING



- ▶ MILITARY VEHICLES
- ▶ OPERATOR PROTECTION
- ▶ VALUE TRANSPORTER
- ▶ BALLISTIC SHIELDS
- ▶ FORMPARTS
- ▶ CUSTOMISE SYSTEMS



© gtn.at



©  
Ressenig Fahrzeugbau GesmbH  
St. Martiner Straße 124  
9500 Villach / Austria

Tel.: +43(0)4242 5010-0  
Fax: +43(0)4242 5010-2  
E-Mail: office@ressenig.at

**RESSENIG**  
ARMOURING TECHNOLOGY

# ADAPTIVE PROTECTION KIT

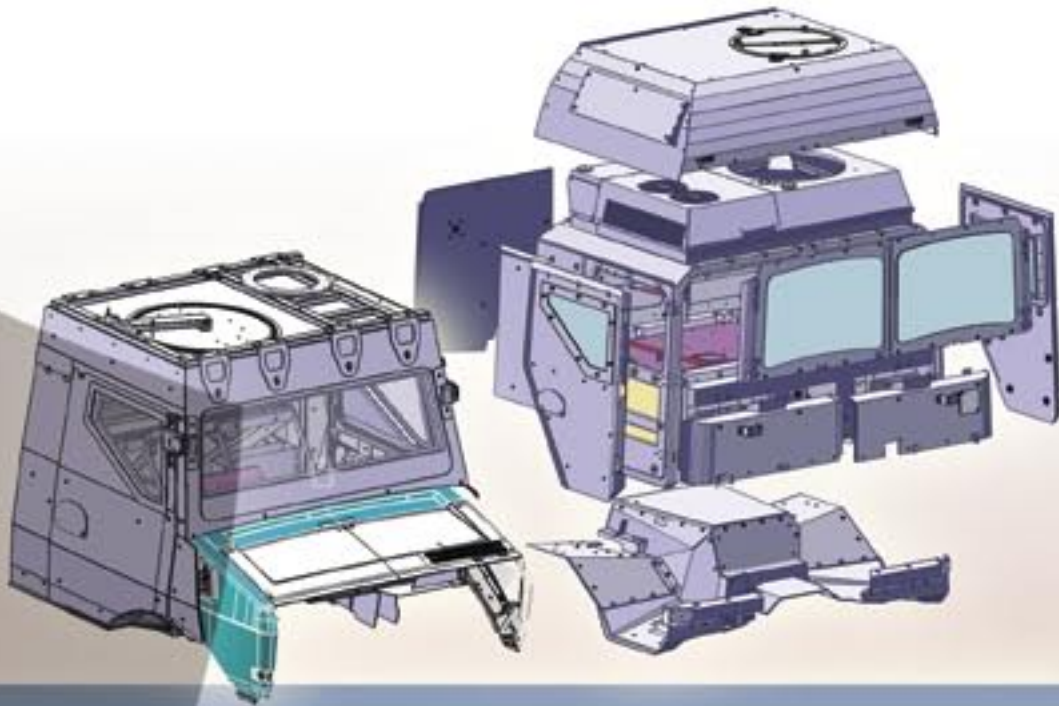

Quality and Safety



# ADAPTIVE PROTECTION KIT



Changing requirements regarding the degree of protection and functionality need an optimal adaptability of the vehicle to all sorts of applications.

Our protection kits with building blocks allow an adaption of the protection level and consequently the greatest possible safety of the team during the active service in crisis areas and for peace-keeping.

The advantages of the greatest possible safety for the team in case of need and at the same time the advantages of the reduction of the running- and maintenance costs during normal operation in a protected vehicle are combined.

The company Ressenig develops, tests and produces adaptive protection kits for logistic- and leading vehicles. According to STANAG protection Levels.



© gtn.at



©  
Ressenig Fahrzeugbau GesmbH  
St. Martiners Straße 124  
9500 Villach / Austria

Tel.: +43(0)4242 5010-0  
Fax: +43(0)4242 5010-2  
E-Mail: [office@ressenig.at](mailto:office@ressenig.at)  
[www.ressenig.at](http://www.ressenig.at)

**RESSENIG**  
ARMOURING TECHNOLOGY

# BALLISTIC SHIELDS



Quality and Safety

# BALLISTIC SHIELDS



Our ballistic protection shields are available in protection classes NIJ or SK.  
We can produce every shape and measurement regarding to your individual requirements.

## Our product range

SK IV+ (80kg) NIJ IV (30kg) NIJ IV (23kg) NIJ IV (15kg) SK III (35kg) SK III (29kg) NIJ III (23kg) NIJ III (15kg) SK II (19kg) SK II (15kg) NIJ IIIa (9kg) SK I+ (6kg)

<p><b>SK IV+ (80kg)</b></p>	<p><b>SK IV (48kg)</b></p>	<p><b>SK IV (29kg)</b></p>	<p><b>SK IV (15kg)</b></p>
<p><b>SK III (35kg)</b></p>	<p><b>SK III (29kg)</b></p>	<p><b>NIJ III (23kg)</b></p>	<p><b>NIJ III (15kg)</b></p>
<p><b>SK II (19kg)</b></p>	<p><b>SK II (15kg)</b></p>	<p><b>NIJ IIIa (9kg)</b></p>	<p><b>SK I+ (6kg)</b></p>



© gtn.at



©  
Ressenig Fahrzeugbau GesmbH  
St. Martiners Straße 124  
9500 Villach / Austria

Tel.: +43(0)4242 5010-0  
Fax: +43(0)4242 5010-2  
E-Mail: office@ressenig.at  
www.ressenig.at

**RESSENIG**  
ARMOURING TECHNOLOGY

# TOYOTA LANDCRUISER



Quality and Safety



# TOYOTA LANDCRUISER



## Discreetly armoured utility vehicle NATO – Class B6

Toyota Land Cruiser 200 series

Engine:	diesel or petrol
Protection:	armoured to level FB6/BR6 acc. Euro norm or on request
Floor:	armoured to defeat 2xDM51 grenades
Overlap:	gap overlap system for splinter protection
Chassis:	extreme heavy suspension system up to 4.500kg GVW
Reinforced:	pillars, posts and hinges
Doors:	chocker to support door-opener and limiter-strap
Options incl.:	intercom system, electric window lift at driver's window, armoured batteries and engine management, run-flat system, emergency exit
Add. Equipment:	individual on custom request



© gtn.at



©  
Ressenig Fahrzeugbau GesmbH  
St. Martiner Straße 124  
9500 Villach / Austria

Tel.: +43(0)4242 5010-0  
Fax: +43(0)4242 5010-2  
E-Mail: [office@ressenig.at](mailto:office@ressenig.at)  
[www.ressenig.at](http://www.ressenig.at)

**RESSENIG**  
ARMOURING TECHNOLOGY

# VALUE TRANSPORTER



Quality and Safety



# VALUE TRANSPORTER



- ▶ Protection class up to B7
- ▶ Run flat system for tyres
- ▶ Design of transportation area on demand
- ▶ Video surveillance system
- ▶ GPS-system.



© gtn.at



©  
Ressenig Fahrzeugbau GesmbH  
St. Martiners Straße 124  
9500 Villach / Austria

Tel.: +43(0)4242 5010-0  
Fax: +43(0)4242 5010-2  
E-Mail: office@ressenig.at  
www.ressenig.at

**RESSENIG**  
ARMOURING TECHNOLOGY